

Vacuum Pumps for moist Gases

INNOVATIVE
TECHNOLOGY
WORLDWIDE

KNF
NEUBERGER



Series N 860.3 FT.40.18 Vacuum Pump

The chemically-resistant series ND 860.3 FT.40.18 diaphragm pump is a twin-head unit with an integrated KNF self-drying system. There is a wide range of applications for this pump in laboratories, especially whenever clean vacuum is required and moist gases must be pumped down. Examples include vacuum-drying of vacuum drying chambers (for drying or heat-treating substances and components) or steam sterilizers for sterilizing instruments, vessels, filters and textiles. Due to its high resistance to aggressive media, this pump can be used universally.

The heart of these very compact pumps are KNF structured diaphragms (PTFE-coated). These patented diaphragms were stress-optimized using the Finite Elements method. As a result, we were able to make the pumps smaller while increasing the service life of the diaphragm.

The KNF self-drying system allows condensed liquid to be blown out of the pump heads at high speed during evacuation. The vacuum in the recipient remains constant.

The drying cycle can be adjusted to the requirements of the individual process using three variables. After drying, the pump reaches a better vacuum and is able to evacuate significantly faster compared with pumps without a drying system.

Self drying Vacuum Pump for moist Gases

Technical features:

- Pure transfer and evacuation
- Highly compatible with vapors and condensation
- Chemically-resistant
- Therefore suitable for highly aggressive or corrosive gases and vapours
- Maintenance-free
- Environmentally friendly
- Gastight, leakage rate approx. 6×10^{-3} mbar x l/s, not tested in serial production.

Material in contact with the pumped media

Type/Order No.	Pump head	Diaphragm	Valves
N 860.3 FT.40.18	PTFE	PTFE-coated	FFPM

Technical data:

	N 860.3 FT.40.18
Delivery (l/min) ¹⁾	60
Ultimate vacuum (mbar abs.)	4
Operating pressure (bar g)	1
Connectors for tube (mm)	ID 12
Permissible gas and ambient temperature	+5...+40 °C
Mains	230V/50Hz
Motor protection	IP 54
Power P ₁	220 W
Operating current	1.6 A
Weight	14.8 kg
Dimensions	
LxHxW (mm)	331/278.5/291
With thermal switch and power fuse	

Motors with other voltages and frequencies on request.

¹⁾ at atm. pressure

Spare parts

Description	Order No.
Spares kit	047499

Vacuum Pumps for moist Gases

INNOVATIVE
TECHNOLOGY
WORLDWIDE

KMF
NEUBERGER



Dimensions and performance characteristics

Pump down time for 20 l receiver

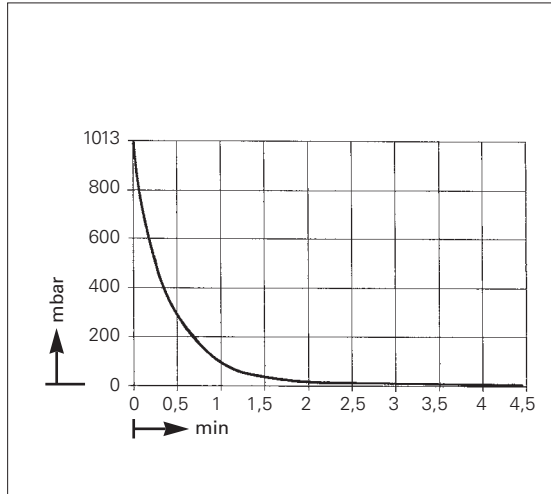

Performance characteristics

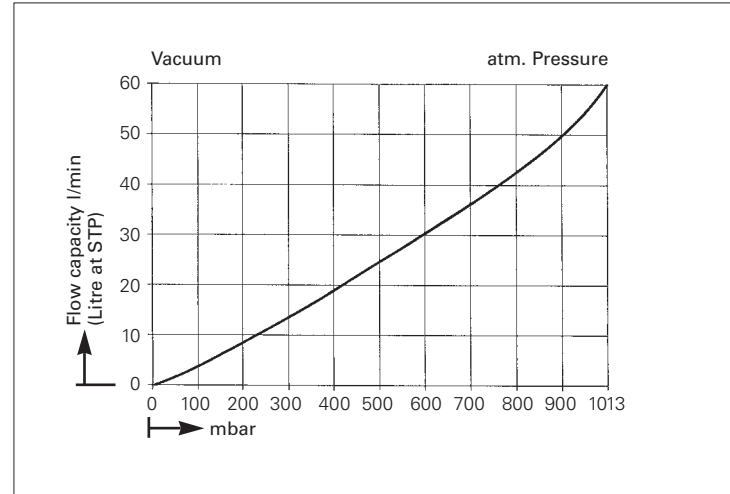

Dimensions (mm)

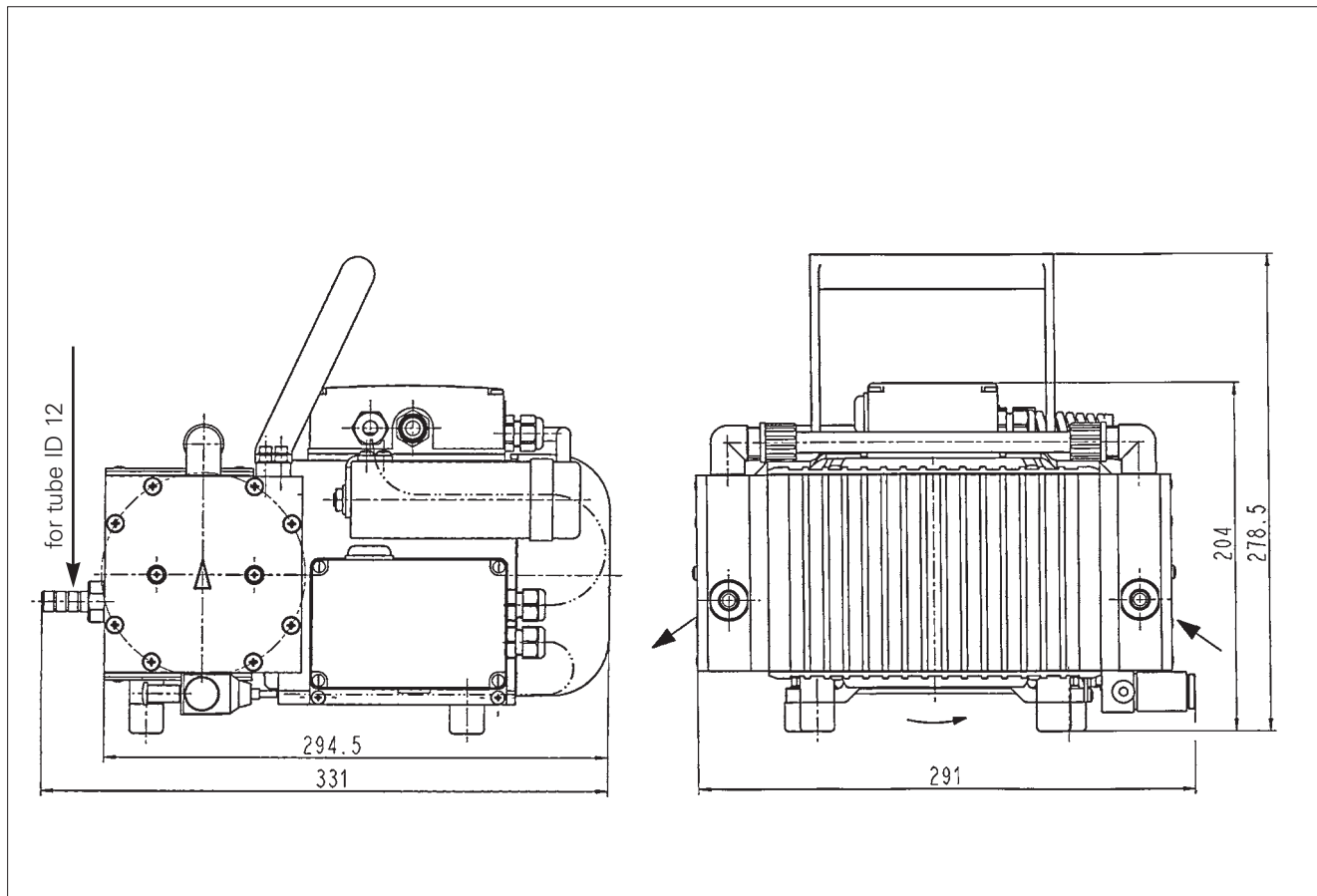



Wolflabs

Wolf Laboratories Limited

www.wolflabs.co.uk

Tel: 01759 301142

Fax: 01759 301143

sales@wolflabs.co.uk



Use the above details to contact us if this literature doesn't answer all your questions.

Pricing on any accessories shown can be found by keying the part number into the search box on our website.

