

Operating Instructions

Read and observe these Operating Instructions!

Diaphragm Vacuum Pumps and Compressors

N035 AN.18
N035 AT.18
N035 AV.18

N035.1.2 AN.18
N035.1.2 AT.18
N035.1.2 AV.18

N035.3 AN.18
N035.3 AT.18
N035.3 AV.18



KNF Neuberger GmbH
Alter Weg 3
79112 Freiburg
Germany
Phone +49-(0)7664 / 5909-0
Fax +49-(0)7664 / 5909-99
E-Mail: info@knf.de
www.knf.de

Contents	Page
1. About this document	3
2. Use	4
3. Safety	5
4. Technical Data	7
5. Design and Function	11
6. Installation and connection.....	13
7. Operation.....	14
8. Servicing.....	16
9. Troubleshooting.....	20
10. Spare parts and accessories.....	22
11. Returns.....	23
12. Health and safety clearance and decontamination form.....	24

1. About this document

1.1. Using the Operating Instructions

The Operating Instructions are part of the pump.

- Carefully study the Operating Instructions before using a pump.
- Always keep the Operating Instructions handy in the work area.
- Pass on the Operating Instructions to the next owner.

Project pumps

Customer-specific project pumps (pump models which begin with "PJ" or "PM") may differ from the Operating Instructions.

- For project pumps, also observe the agreed upon specifications.

1.2. Symbols and Markings

Warning



WARNING

A danger warning is located here.

Possible consequences of a failure to observe the warning are specified here. The signal word, e.g.

Warning, indicates the danger level.

- Measures for avoiding the danger and its consequences are specified here.

Danger levels

Signal word	Meaning	Consequences if not observed
DANGER	warns of immediate danger	Death or serious injuries and/or serious damage are the consequence.
WARNING	warns of possible danger	Death or serious injuries and/or serious damage are possible.
CAUTION	warns of a possibly dangerous situation	Minor injuries or damage are possible.

Tab. 1

Other information and symbols

- An activity to be carried out (a step) is specified here.
- 1. The first step of an activity to be carried out is specified here. Additional, consecutively numbered steps follow.
- i** This symbol refers to important information.

2. Use

2.1. Proper use

The pumps are exclusively intended for transferring gases and vapors.

Owner's responsibility

Operating parameters and conditions

Only install and operate the pumps under the operating parameters and conditions described in Chapter 4, Technical data.

Make sure that the installation location is dry and the pump is protected against rain, splash, hose and drip water.

Requirements for transferred medium

Before using a medium, check whether the medium can be transferred danger-free in the specific application case.

Before using a medium, check the compatibility of the materials of the pump head, diaphragm and valves with the medium.

Only transfer gases which remain stable under the pressures and temperatures occurring in the pump.

2.2. Improper use

The pumps may not be operated in an explosive atmosphere.

The pumps are not suitable for transferring dusts.

The pumps are not suitable for transferring liquids.

Pumps designed to create either a vacuum or an overpressure must not be used for these two purposes simultaneously.

An overpressure must not be applied to the suction side of the pump.

3. Safety

i Note the safety precautions in sections 6. *Installation and connection*, and 7. *Operation*.

The pumps are built according to the generally recognized rules of technology and in accordance with the occupational safety and accident prevention regulations. Nevertheless, dangers can result during their use which lead to injuries to the user or others, or to damage to the pump or other property.

Only use the pumps when they are in a good technical and proper working order, in accordance with their intended use, observing the safety advice within the operating instructions, at all times.

Personnel

Make sure that only trained and instructed personnel or specially trained personnel work on the pumps. This especially applies to assembly, connection and servicing work.

Make sure that the personnel has read and understood the operating instructions, and in particular the "Safety" chapter.

Working in a safety-conscious manner

Observe the accident prevention and safety regulations when performing any work on the pump and during operation.

Do not expose any part of your body to the vacuum.

Open housing parts with notice sticker (see fig. 1) only after separating mains plug from power source.

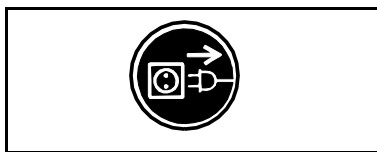

Fig. 1: Notice sticker

Handling dangerous media

When transferring dangerous media, observe the safety regulations when handling these media.

Handling flammable media

Be aware that the pumps are not designed to be explosion-proof.

Make sure the temperature of the medium is always sufficiently below the ignition temperature of the medium, to avoid ignition or explosion. This also applies for unusual operational situations.

Note that the temperature of the medium increases when the pump compresses the medium.

Hence, make sure the temperature of the medium is sufficiently below the ignition temperature of the medium, even when it is compressed to the maximum permissible operating pressure of the pump. The maximum permissible operating pressure of the pump is stated in the technical specifications (see section 4).

If necessary, consider any external sources of energy, such as radiation, that may add heat to the medium.

In case of doubt, consult the KNF customer service.

Environmental protection

Store all replacement parts in a protected manner and dispose of them properly in accordance with the applicable environmental protection regulations. Observe the respective national and international regulations. This especially applies to parts contaminated with toxic substances.

Standards	<p>The pumps conform to the Directive 2011/65/EU (RoHS2).</p> <p>The pumps conform to the safety regulations of the Directive 2014/30/EU concerning Electromagnetic Compatibility and the Directive 2006/42/EG concerning Machinery.</p> <p>The following harmonized standards have been used:</p> <ul style="list-style-type: none">▪ DIN EN 60204-1▪ DIN EN 61326-1 - class A▪ DIN EN 50581
Customer service and repairs	<p>Only have repairs to the pump carried out by the KNF Customer Service responsible.</p> <p>Only authorized personnel should open those parts of the housing that contain live electrical parts.</p> <p>Use only genuine parts from KNF for servicing work.</p>

4. Technical Data

Pump materials

Pump type	Material			
	Pump head	Diaphragm	Valve	Gasket
N 035 AN.18	Aluminium	CR	Stainless steel	CR
N 035.1.2 AN.18				
N 035.3 AN.18				
N 035 AT.18	Aluminium	PTFE-coated	Stainless steel	FPM
N 035.1.2 AT.18				
N 035.3 AT.18				
N 035 AV.18	Aluminium	FPM	Stainless steel	FPM
N 035.1.2 AV.18				
N 035.3 AV.18				

Tab. 2

Pneumatic Values

Pump type	Delivery rate* at atm. pressure (l/min)	Maximal operating pressure (bar g)	Ultimate vacuum (mbar abs.)
N 035 AN.18	30	4	100
N 035 AT.18	27		
N 035 AV.18	30	2	
N 035.1.2 AN.18	55	4	
N 035.1.2 AT.18	50		
N 035.1.2 AV.18	55	2	
N 035.3 AN.18	30	-	13
N 035.3 AT.18	27	-	20
N 035.3 AV.18	30	-	13

Tab. 3

*Liters in standard state (1013 mbar)

Electrical Data 100 V versions

Pump Type*	Voltage [V]	Frequency [Hz]	Power P1 [W]	Operating current [A]
N 035 AN.18 IP 20	100	50/60	250	2.7
N 035 AT.18 IP 20				
N 035 AV.18 IP 20				
N 035 AN.18 IP 44	100	50/60	230	3.4
N 035 AT.18 IP 44				
N 035 AV.18 IP 44				
N 035.1.2 AN.18 IP 20	100	50/60	300	3.5
N 035.1.2 AT.18 IP 20				
N 035.1.2 AV.18 IP 20				
N 035.1.2 AN.18 IP 44	100	50/60	360	4.8
N 035.1.2 AT.18 IP 44				
N 035.1.2 AV.18 IP 44				
N 035.3 AN.18 IP 20	100	50/60	300	3.5
N 035.3 AT.18 IP 20				
N 035.3 AV.18 IP 20				
N 035.3 AN.18 IP 44	100	50/60	360	4.8
N 035.3 AT.18 IP 44				
N 035.3 AV.18 IP 44				

Tab. 4

*see type plate

Electrical Data 115 V versions

Pump Type*	Voltage [V]	Frequency [Hz]	Power P1 [W]	Operating current [A]
N 035 AN.18 IP 20	115	50	220	2
N 035 AT.18 IP 20				
N 035 AV.18 IP 20				
N 035 AN.18 IP 44	115	50	230	2.7
N 035 AT.18 IP 44				
N 035 AV.18 IP 44				
N 035.1.2 AN.18 IP 20	115	50	300	3
N 035.1.2 AT.18 IP 20				
N 035.1.2 AV.18 IP 20				
N 035.1.2 AN.18 IP 44	115	50	330	3.4
N 035.1.2 AT.18 IP 44				
N 035.1.2 AV.18 IP 44				
N 035.3 AN.18 IP 20	115	50	300	3
N 035.3 AT.18 IP 20				
N 035.3 AV.18 IP 20				
N 035.3 AN.18 IP 44	115	50	330	3.4
N 035.3 AT.18 IP 44				
N 035.3 AV.18 IP 44				

Tab. 5

*see type plate

Electrical Data 230 V versions

Pump Type*	Voltage [V]	Frequency [Hz]	Power P1 [W]	Operating current [A]
N 035 AN.18 IP 20	230	50	220	1
N 035 AT.18 IP 20				
N 035 AV.18 IP 20				
N 035 AN.18 IP 44	230	50	230	1.7
N 035 AT.18 IP 44				
N 035 AV.18 IP 44				
N 035.1.2 AN.18 IP 20	230	50	300	1.55
N 035.1.2 AT.18 IP 20				
N 035.1.2 AV.18 IP 20				
N 035.1.2 AN.18 IP 44	230	50	320	1.9
N 035.1.2 AT.18 IP 44				
N 035.1.2 AV.18 IP 44				
N 035.3 AN.18 IP 20	230	50	300	1.55
N 035.3 AT.18 IP 20				
N 035.3 AV.18 IP 20				
N 035.3 AN.18 IP 44	230	50	320	1.9
N 035.3 AT.18 IP 44				
N 035.3 AV.18 IP 44				

Tab. 6

*see type plate

The pumps are fitted as standard with a thermal-switch to protect against overloading.

Other parameters

<i>Pneumatic connections</i>	
Hose connections N 035._ A _.18 [mm]	ID 9
<i>Ambient and media temperature</i>	
Permissible ambient temperature	+ 5 °C to + 40 °C
Permissible media temperature	+ 5 °C to + 40 °C
<i>Other parameters</i>	
Maximum permissible ambient relative humidity	80 % for temperatures up to 31°C, decreasing linearly to 50 % at 40°C
Max. altitude of site [m above sea level]	2000
Maximum permitted mains voltage fluctuations	+/- 10 %
<i>Weight</i>	
N 035 A_.18 [kg]	8.5
N 035._ A_.18 IP20 [kg]	11.5
N 035._ A_.18 IP44 [kg]	12
<i>Dimensions</i>	
N 35 A_.18 IP20 L x H x W [mm]	265 x 254 x 143
N 035.1.2 A_.18 IP20 L x H x W [mm]	321 x 222 x 250
N 035.3 A_.18 IP20 L x H x W [mm]	323 x 222 x 250
N 35 A_.18 IP44 L x H x W [mm]	280 x 255 x 198
N 035.1.2 A_.18 IP44 L x H x W [mm]	349 x 222 x 250
N 035.3 A_.18 IP44 L x H x W [mm]	351 x 222 x 250

Tab. 7

5. Design and Function

Design N 035 A_.18

- 1 Pneumatic pump outlet
- 2 Pneumatic pump inlet
- 3 On/Off Switch
- 4 Handle

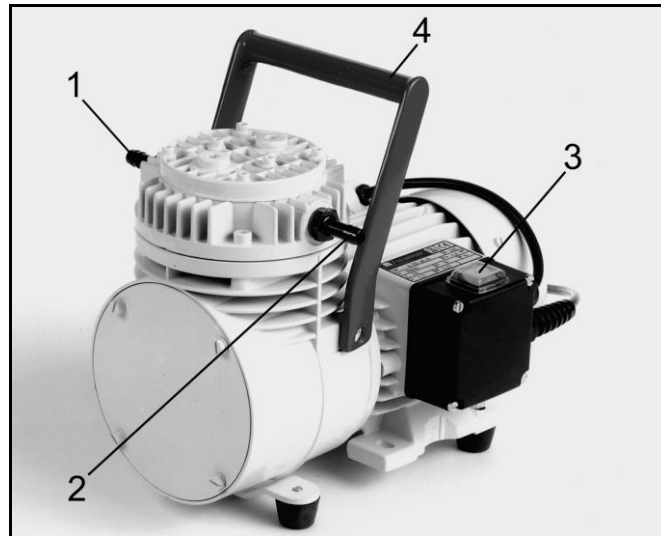

Fig. 2: Diaphragm Pump N 035 AN.18

Design N 035.1.2 A_.18

- 1 Pneumatic pump outlet
- 2 Pneumatic pump inlet
- 3 On/Off Switch
- 4 Pneumatic head connection 1
- 5 Handle
- 6 Pneumatic head connection 2

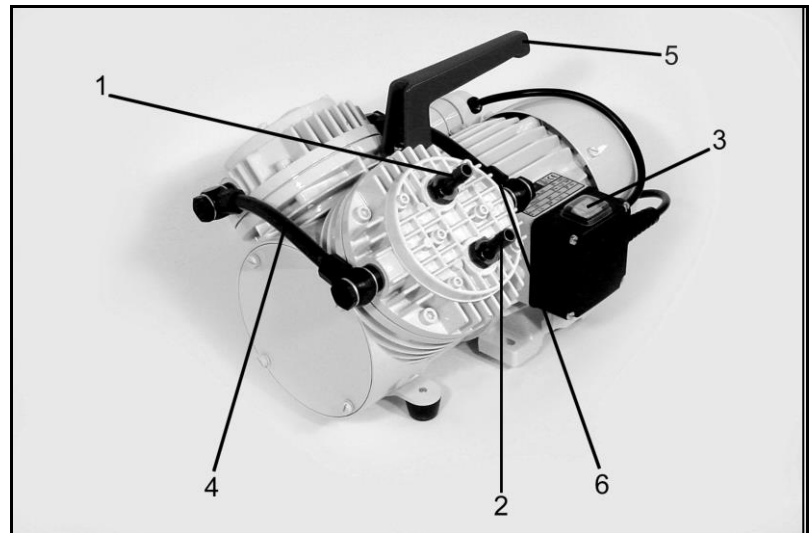

Fig. 3: Diaphragm Pump N 035.1.2 AN.18

Design N 035.3 A_.18

- 1 Pneumatic pump outlet
- 2 Pneumatic pump inlet
- 3 On/Off Switch
- 4 Handle
- 5 Pneumatic head connection
- 6 Silencer/filter (accessory)

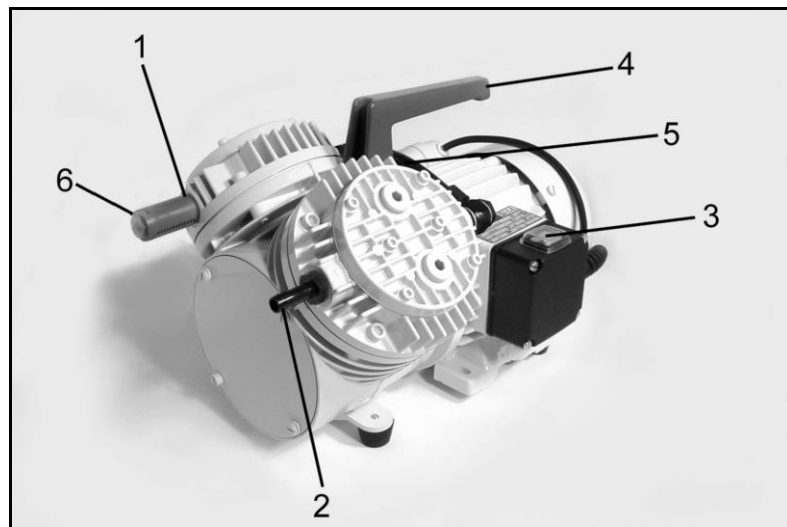

Fig. 4: Diaphragm pump N 035.3 AN.18

Function diaphragm pump

- 1 Outlet valve
- 2 Inlet valve
- 3 Transfer chamber
- 4 Diaphragm
- 5 Eccentric
- 6 Connecting rod
- 7 Pump drive

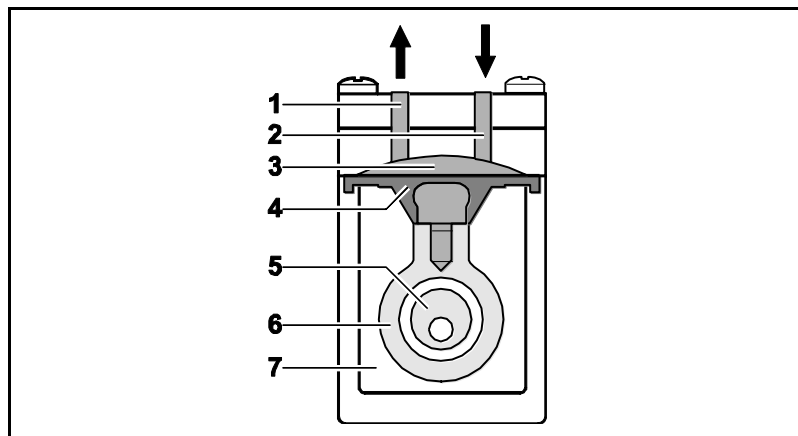

Fig. 5: Pump head

The pump transfers, compresses (depending on pump version) and evacuates gases and vapors.

The elastic diaphragm (4) is moved up and down by the eccentric (5) and the connecting rod (6). In the downward stroke it aspirates the gas to be transferred via the inlet valve (2). In the upward stroke, the diaphragm presses the medium out of the pump head via the outlet valve (1). The transfer chamber (3) is hermetically separated from the pump drive (7) by the diaphragm.

6. Installation and connection

Only install and operate the pumps under the operating parameters and conditions described in chapter 4, Technical data.

Observe the safety precautions (see chapter 3).

6.1. Installation

- Before installation, store the pump at the installation location to bring it up to room temperature.
- Dimensions → See chapter 4, Technical data, for the dimensions of pump.
- Cooling air supply → Install the pump so that the motor fan can intake sufficient cooling air.
- Installation location → Make sure that the installation location is dry and the pump is protected against rain, splash, hose and drip water.
- Choose a safe location (flat surface) for the pump.
- Protect the pump from dust.
- Protect the pump from vibrations and jolts.

6.2. Connection

- Connected components → Only connect components to the pump which are designed for the pneumatic data of the pump (see section 4).
- Pump exhaust → If the pump is used as a vacuum pump, safely discharge the pump exhaust at the pump's pneumatic outlet.
- Connection
 - i** A marking on the pump head shows the direction of flow.
 - 1. Remove the protective plugs from the pneumatic connectors of the pump.
 - 2. Mount accessory silencer/filter (where applicable):
 - i** If the pump is used as a vacuum pump, mount the silencer at the pressure side if necessary. If the pump is used as a compressor (not permitted with series N 035.3) mount the filter at the suction side if necessary.
 - Unscrew corresponding hose connector from pump head.
 - Screw silencer/filter into pump head.
 - 3. Connect the suction line and pressure line (tube inner diameter 9 mm).
 - 4. Lay the suction and pressure line at a downward angle to prevent condensate from running into the pump.
 - 5. Insert the power cable's plug into a properly installed shockproof socket.

7. Operation

7.1. Preparing for Start-up

Before switching on the pump, observe the following points:

	Operational requirements
Pump	All hoses attached properly Fan openings not blocked Specifications of the power supply correspond with the data on the pump's type plate. The pump outlet is not closed or constricted.

Tab. 8

7.2. Starting

- Only operate the pump under the operating parameters and conditions described in chapter 4, Technical data.
- Make sure the pump is used properly (see section 2.1).
- Make sure the pump is not used improperly (see section 2.2).
- Observe the safety precautions (see chapter 3).



WARNING

Hazard of the pump head bursting due to excessive pressure increase

- Do not exceed max. permissible operating pressure (see section 4).
- Monitor pressure during operation.
- If the pressure exceeds the maximum permissible operating pressure, immediately shut down pump and eliminate fault (see chapter 9. Troubleshooting).
- Only throttle or regulate the air or gas quantity in the suction line to prevent the maximum permissible operating pressure from being exceeded.
- If the air or gas quantity in the pressure line is throttled or regulated, make sure that the maximum permissible operating pressure of the pump is not exceeded.

i Excessive pressure (with all of the related hazards) can be prevented by placing a bypass line with a pressure-relief valve between the pressure and suction side of the pump. For further information, contact our technical adviser.

- Pump standstill → With the pump at a standstill, open pressure and suction lines to normal atmospheric pressure.

**WARNING**

Automatic starting can cause personal injury and pump damage

When the operation of the pump is interrupted by the thermal switch, the pump will restart automatically after cooling down.

- After triggering of the thermal protection or in the event of power failure, remove the pump's mains plug from the socket so that the pump cannot start uncontrollably.
 - Attempt work on the pump only if the pump is separated from mains power.
-

7.3. Switching pump on and off

Switching pump on

i The pump may not start up against pressure or vacuum during switch-on. This also applies in operation following a brief power failure. If a pump starts against pressure, it may block. This activates the thermal switch, and the pump switches off.

- Make sure that no pressure or vacuum is present in the lines during switch-on.
- Switch on pump with mains switch (see fig. 2, 3 or 4, position 3).

Switching off the pump/removing from operation

- When transferring aggressive media, flush the pump prior to switch-off to increase the service life of the diaphragm (see section 8.2.1).
- Switch off pump with mains switch (see fig. 2, 3 or 4, position 3).
- Open pressure and suction lines to normal atmospheric pressure.

8. Servicing

8.1. Servicing Schedule

Component	Servicing interval
Pump	Regular inspection for external damage or leaks
Diaphragm, reed valves (valve plate)	Replace at the latest, when pump output decreases
Silencer/filter (accessory)	Change if it is dirty

Tab. 9

8.2. Cleaning

i When cleaning, make sure that no liquids enter the inside of the housing.

8.2.1. Flushing Pump

→ Before switching off the pump, flush it with air (if necessary for safety reasons: with an inert gas) for about five minutes under atmospheric conditions (ambient pressure).

8.2.2. Cleaning Pump

→ Only use solvents for cleaning if the head materials cannot be attacked (check the resistance of the material!).

→ If compressed air is available, blow out the components.

8.3. Changing Diaphragm and Valves

- Conditions
- Pump is switched off and mains plug is removed from the socket
 - Pump is clean and free of hazardous materials
 - Tubes removed from pump's pneumatic inlet and outlet

Spare parts

Spare part*	Position**	Quantity per pump head
Diaphragm	(F)	1
Countersunk screw	(D)	1
Reed valve	(M,P)	2
Gasket	(V)	1

Tab. 10

*According to Spare parts list, chapter 10

**According to Fig. 6.

Tools

Quantity	Tools/Material
1	Allen key 3 mm
1	Allen key 4 mm
1	Allen key 5 mm
1	Screwdriver blade width 6.5
1	Screwdriver blade width 4.0
1	Fork wrench 16 mm (only for two-headed pumps)
1	Pencil

Tab. 11

Information on procedure

With multi-head pumps, parts of the individual pump heads can be confused.

- Replace the diaphragm and reed valves of the individual pump heads consecutively.



WARNING

Health hazard due to dangerous substances in the pump!

Depending on the substance transferred, caustic burns or poisoning are possible.

- Wear protective clothing if necessary, e.g. protective gloves.
- Flush pump before replacing the diaphragm and reed valves (see section 8.2.1).

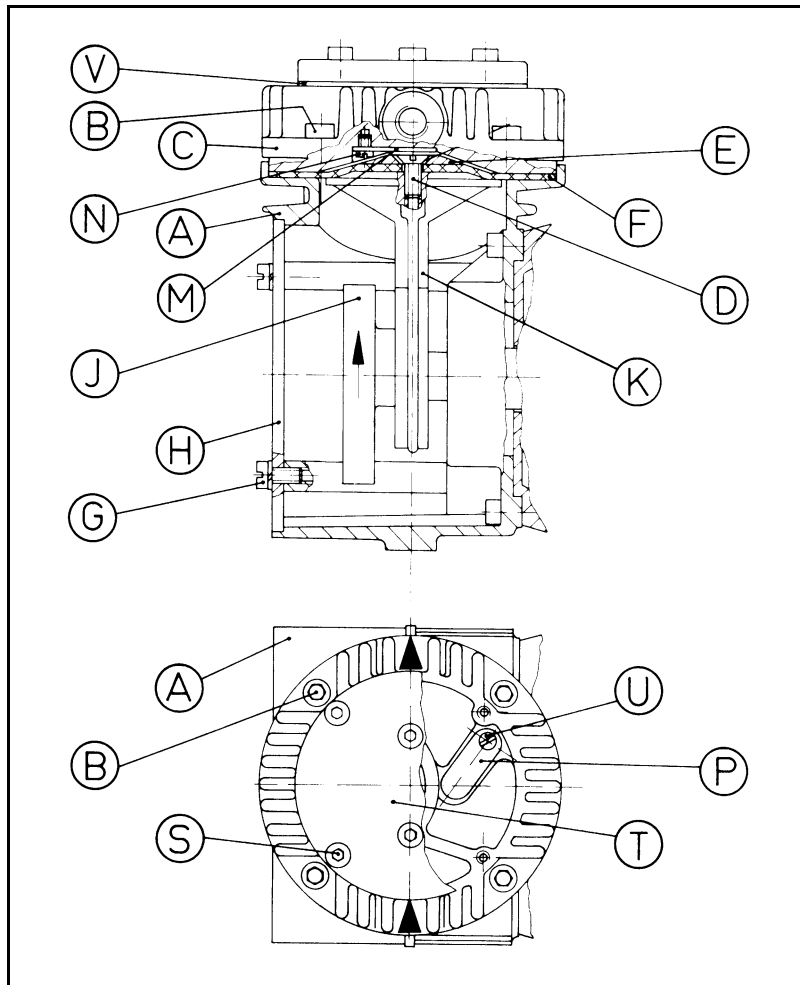

Fig. 6: Pump parts for versions with aluminium head

1. For pumps N 035.1.2 A_.18:
On both pneumatic head connections, open the head connection union nut on one pump head and pull the hose off.
2. For pumps N 035.3 A_.18:
At one pump head open the union nut of pneumatic connection and pull off the tube.
3. Mark the position of the diaphragm head C in relation of the housing A with a pencil.
4. Loosen the four allen screws B and remove the diaphragm head C.
5. Unscrew the countersunk screw D, remove the retainer plate E and the diaphragm F.
6. Loosen the four screws G and remove the cover plate H.
7. Turn the counterweight J so that the connection rod K is in the mid-position; fit the new diaphragm F.
8. Place the retainer plate E on the diaphragm F and carefully but firmly tighten the new countersunk screw D (torque: 5.0 Nm).

i The self-locking screw D can only be used once.

9. Change lower reed valve:
 - Undo the cheese head screw N and exchange the reed valve M.
 10. Change upper reed valve:
 - Loosen the allen screws S, remove the cover plate T and the gasket V.
 - Undo the cheese head screw U and exchange the reed valve P; tighten the cheese head screw U.
 - Replace the cover plate T with a new gasket V and tighten the allen screws S.
 11. Place the diaphragm head C according to the marks made previously and tighten the screws B uniformly and diagonally (torque: 10.0 Nm).
 12. Turn the counterweight J to check that the pump run freely.
 13. For two-headed pumps:
Carry out steps 3 to 12 for the second pump head.
 14. Replace the cover plate H and secure it with the four screws G.
 15. For two-headed pumps:
Reattach the tube of pneumatic head connection onto the hose connector and tighten the union nut.
- i** For N 035.1.2 A_.18 pumps, this applies to both pneumatic head connections.

9. Troubleshooting



Extreme danger from electrical shock!

→ Disconnect the pump power supply before working on the pump.

DANGER

→ Make sure the pump is de-energized and secure.

→ Check the pump (see Tab. 12 to 15).

Pump does not transfer	
Cause	Fault remedy
No voltage in the power source	→ Check room fuse and switch on if necessary.
Thermal switch has operated following to over-heating.	→ Disconnect pump from mains. → Allow pump to cool. → Trace cause of over-heating and eliminate it.
Connections or lines blocked.	→ Check connections and lines. → Remove blockage.
External valve is closed or filter is clogged.	→ Check external valves and filters.
Condensate has collected in pump head.	→ Detach the condensate source from the pump. → Flush pump (see Section 8.2.1).
Diaphragm or reed valves (valve plate) are worn.	→ Replace diaphragm and reed valves (valve plate), (see Section 8.3).

Tab. 12

Flow rate, pressure or vacuum too low	
The pump does not achieve the output specified in the Technical data or the data sheet.	
Cause	Fault remedy
Condensate has collected in pump head.	→ Detach the condensate source from the pump. → Flush pump (see Section 8.2.1).
There is gauge pressure on pressure side and at the same time vacuum or a pressure above atmospheric pressure on suction side.	→ Change the pressure conditions.
Pneumatic lines or connection parts have an insufficient cross section.	→ Disconnect pump from system to determine output values. → Eliminate throttling (e.g. valve) if necessary. → Use lines or connection parts with larger cross section if necessary.
Leaks occur on connections, lines or pump head.	→ Check that tubes sit correctly on hose nozzles. → Replace leaky tubes. → Eliminate leaks.
Connections or lines completely or partially jammed.	→ Check connections and lines. → Remove the jamming parts and particles.
Head parts are soiled.	→ Clean head components.
Diaphragm or reed valves (valve plate) are worn.	→ Replace diaphragm and reed valves (valve plate), (see Section 8.3).

Flow rate, pressure or vacuum too low	
The pump does not achieve the output specified in the Technical data or the data sheet.	
Cause	Fault remedy
After diaphragm and reed valves (valve plate) have been replaced	<ul style="list-style-type: none"> ➔ Check the tubing for leaks. ➔ Possibly carefully tighten the screws (B) and (S) (see fig. 6) crosswise.

Tab. 13

Pump is switched on, but does not run, the on/off-switch on the pump is not lit	
Cause	Fault remedy
Pump is not connected with the power source.	➔ Connect pump to mains power.
No voltage in the power source	➔ Check room fuse and switch on if necessary.

Tab. 14

Pump is switched on, but does not run, the on/off-switch on the pump is lit	
Cause	Cause
The thermal switch has opened due to overheating	<ul style="list-style-type: none"> ➔ Remove pump's mains plug from the socket. ➔ Allow pump to cool. ➔ Trace cause of over-heating and eliminate it.

Tab. 15

Fault cannot be rectified

If you are unable to determine any of the specified causes, send the pump to KNF Customer Service (see last page for the address).

1. Flush the pump to free the pump head of dangerous or aggressive gases (see Section 8.2.1).
2. Clean the pump (see Section 8.2.2).
3. Send the pump, together with completed Health and Safety Clearance and Decontamination Form (Chapter 12), to KNF stating the nature of the transferred medium.

10. Spare parts and accessories

Spare parts

N 035 AN.18 N 035.1.2 AN.18 N 035.3 AN.18

Spare part	Position*	Order No.
Diaphragm	(F)	001312
Countersunk screw	(D)	110711
Reed valve	(M, P)	001328
Gasket	(V)	001326

Tab. 16

According to Fig. 6

N 035 AT.18 N 035.1.2 AT.18 N 035.3 AT.18

Spare part	Position*	Order No.
Diaphragm	(F)	001406
Countersunk screw	(D)	110711
Reed valve	(M, P)	001328
Gasket	(V)	011796

Tab. 17

According to Fig. 6

N 035 AV.18 N 035.1.2 AV.18 N 035.3 AV.18

Spare part	Position*	Order No.
Diaphragm	(F)	001405
Countersunk screw	(D)	110711
Reed valve	(M, P)	001328
Gasket	(V)	011796

Tab. 18

According to Fig. 6

Accessories

Accessory	for pump type	Order No.
Silencer/filter (G ¼)	all	000352
Pressure relief valve 4 bar	N 035 AN.18 N 035.1.2 AN.18	047601
Fine control valve with pressure gauge, pressure side	N 035 AN.18 N 035.1.2 AN.18	000482
Fine control valve with vacuum gauge, suction side	N 035 AN.18 N 035.1.2 AN.18 N 035.3 AN.18	000354

Tab. 19

11. Returns

Pumps and systems used in laboratories and process-based industries are exposed to a wide variety of conditions. This means that the components contacting pumped media could become contaminated by toxic, radioactive, or otherwise hazardous substances.

For this reason, customers who send any pumps or systems back to KNF must submit a Health and safety clearance and decontamination form in order to avoid a hazardous situation for KNF employees. This Health and safety clearance and decontamination form provides the following information, among other things:

- physiological safety
- whether medium-contacting parts have been cleaned
- whether the equipment has been decontaminated
- media that have been pumped or used

To ensure worker safety, work may not be started on pumps or systems without a signed Health and safety clearance and decontamination form.

For optimal processing of a return, a copy of this declaration should be sent in advance via e-mail, regular mail, or fax to KNF Customer Service (refer to final page for address). In order to avoid endangering employees who open the shipment's packaging, despite any residual hazards, the original version of the Health and safety clearance and decontamination form must accompany the delivery receipt on the outside of the packing.

The template for the Health and safety clearance and decontamination form is included with these Operating Instructions and may also be downloaded from the KNF website.

The customer must specify the device type(s) and serial number(s) in the Health and safety clearance and decontamination form in order to provide for the unambiguous assignment of the Declaration to the device that is sent to KNF.

In addition to the customer's declaration of physiological safety, information about operating conditions and the customer's application are also of importance to ensure that the return shipment is handled appropriately. Therefore, the Health and safety clearance and decontamination form requests this information as well.

12. Health and safety clearance and decontamination form



Form: Rev. 02 / download: www.knf.com

Health and safety clearance and decontamination form

This declaration must be present and complete (the original must accompany the shipment's delivery receipt) before the returned device can be examined.

Device type:

Serial number(s):
.....
.....

Reason for returning the device (please describe in detail):

(The device(s) was(were) in operation yes no)
.....
.....
.....
.....

We confirm that the above device(s)

has(have) pumped exclusively **physiologically unobjectionable** media and that it(they) are free of hazardous materials and any materials that are harmful to health.

Pumped media:

The device(s) was(were) cleaned yes no

has(have) pumped media of the following category(categories) which are not physiologically unobjectionable and that cleaning of the device(s) (potentially only media-contacting parts) is required.

Name, chemical formula, Material Safety Data Sheet

- aggressive
- biological
- radioactive
- toxic
- other

The device(s) was(were) decontaminated and work can proceed without special measures yes

Method / proof:
.....

The device(s) was(were) not decontaminated and special measures are required before starting work yes

Measures:
.....

Legally binding declaration

We herewith affirm that the information provided in this form is correct and complete. Shipment of the devices and components is in compliance with statutory regulations.

.....
Company (stamp) Date Name Authorized signature Position